

| Technical information | |
|-----------------------------------|--|
| Cable light | KL1256 |
| Material | Aluminium* |
| Size | Round 68 x 200mm |
| Weight above water | 0,5 kg |
| Weight under water | 0,1 kg |
| Bulb type | Halogen Xenophot 12 Volt - 50 Watt GY6,35 |
| Optional light power installation | 24 Watt LED Unit |
| Variable light power | 0-100% |
| Cable lenght | 100 cm. |

| Battery tank | FX1204 | Pr1206 / FX1206 | Pr1209 / FX1209 | PR1213 |
|---------------------------------|-------------------|------------------|------------------|------------------|
| Material | Aluminium* | Aluminium* | Aluminium* | Aluminium* |
| Seize | 65 x 75 x 230 | 65 x 75 x 340 | 65 x 75 x 340 | 65 x 75 x 480 |
| Weight above water | 1,6 kg | 2,7 kg / 2,3 kg | 2,9 kg / 2,5 kg | 3,7 kg |
| Weight under water | 1,0 kg | 1,6 kg / 1,3 kg | 1,7 kg / 1,4 kg | 2,7 kg |
| Battery type | NiMH | Nicad | NiMH | NiMH |
| Battery power | 12 Volt 3,8 Ah | 12 Volt 5,5 Ah | 12 Volt 9 Ah | 12 Volt 13 Ah |
| Charger | MP1100 / MP2500 | MP1100 | MP2500 | MP2500 |
| Charging time | appr. 4 / 2 hours | appr. 6 hours | appr. 4,5 hours | appr. 7 hours |
| Capacity normal (at 50 Watt) | appr. 40 min.** | appr. 65 min.** | appr. 110 min.** | appr. 180 min.** |
| Capaciteit met 24 Watt LED unit | appr. 90 min.** | appr. 140 min.** | appr. 230 min.** | appr. 380 min.** |
| Quick release systeem | no | yes / no | yes / no | yes |
| Hyperbaric pressure test | 25 bar | 25 bar | 25 bar | 25 bar |

* In accordance with American Military Standard MIL-A-8625-E type 3 class 2.
Also the coating is impregnated with Teflon.

** Measured by 100% power and water temperature 20°Celsius.

Warranty

The Metalsub torch warranty will start on the date of purchase. The warranty period is two years and will only count when the torch has been used in the way the manufacture advises and has explained in the outlines. During this warranty period we will repair all problems that are caused by manufacture related mistakes. We will take no responsibility for damage that is done through misuse or normal wear and tear of the Metalsub diving light for whatever reason. The warranty period of the battery pack is 12 months from production date, with the same remarks for misuse. Until 36 months from purchase we offer a fair settlement. The light bulb itself has no warranty! We will give no warranty when any person has carried out any repair or rebuilding on our products by themselves!

dealer



The Netherlands



METALSUB - CABLE LIGHT KL1256 CE⁰⁷

Battery tank PR1206 / PR1209 / PR1213
Battery tank FX1204 / FX1206 / FX1209

SAFETY PRECAUTIONS!

- A. Read this manual carefully before using the delvamp
- B. When you are diving in situations where your life can depend on having sufficient light (for instance in caves or on wrecks), make sure you always take a back-up light with you.
- C. Prior to airtravel, disconnect the cablelamp from the battery pack, so as to prevent overheating should the lamp be switched on by accidental impact or mishandling. Also discharge the battery pack.
- D. To prevent a short-circuit, it is essential to plug the battery tank with the supplied tankplug(s).
- E. Always use the supplied charger.
- F. Charging the lamp: - always in a dry and well ventilated place
- ambient temperature between 0 and 30°C
- never by open fire
- G. When changing lights, always disconnect the light from the battery tank first.
- H. Never shine the light directly into eyes, this can cause eye damage.

HOW TO USE THE DIVE LIGHT:

Charging the battery pack

The charger is suitable for mains between 100-240 Vac. We deliver the battery pack empty, so it is important to charge the empty pack completely with a full charge cycle.

Make sure that the connector is clean and dry. Securely plug the charge connector into the battery tank.

The charger is fitted with a Delta-V charge controller. The charge controller switches over to pulse charging as soon as the battery reaches its full power. Please wait until the small light (LED) on the charger lights green continuously before you disconnect the charger from the battery pack.

Battery test: the LED indication will flash red 5 sec.

Charging: The LED indication lights red continuously.

Battery pack full / trickle charge: the LED indication lights green continuously.

Warning:

Always use the charger that is delivered with the dive light!!! The use of other chargers can damage the battery cells inside!!!

Connection the cable light onto the battery tank

The connection of the cable-light to the battery pack is done by placing the connector in the water seal connector seat on the battery pack. The connection is made with a little inward push and a turn to the right. Disconnection is done by doing the same sequence in reverse.

Make sure that the connectors are completely clean and dry. When necessary, clean the O-ring and use a little bit of silicone grease to produce a better water tight seal.

Warning:

Never disconnect the the light from the battery pack under water!!!! This will damage the connector inside the battery pack!!!!!!

Switching the cable light on and off

The light is switched on by sliding the locking bolt on the switch backwards and then turning the switch to the right (90 degrees).

The light power varies from 0 until 100%. When the switch is turned about 45 degrees you can feel a heavy point, which indicates approximately 50% light power. To turn the light off, rotate the switch back to the left until it clicks into the off position. To lock the light, slide the locking bolt back and rotate the switch to the left until it clicks (locks) into the locked position.

The LED display on the back of the lamp housing tells you the following:

| | |
|-------------------|---|
| LED green: | 100% - 50% remain capacity |
| LED orange: | 50% - 20% remain capacity |
| LED red: | 20% - 10% remain capacity |
| LED red blinking: | 10% - 0% remain capacity left: the light will automatically drop down to 50% capacity (10 minutes are left before the light switches off) |

Note: These values are guiding values only and depend very much on water temperatures and the type of battery tank! The values shown above were measured at a water temperature of 20°Celsius. In colder water (for instance 10°Celsius or less) the LED light will go from green to orange in just a few minutes.

Remark:

If you don't use the torch for a longer time we advise you to disconnect the cable-light from the battery pack to prevent discharging of the battery pack.

Never store the battery pack uncharged for a long period. If the battery pack is not used for a long period, we advise you first to charge the battery pack completely and then every three months to dis- and recharge the battery pack completely.

Removal of the halogen light unit/LED unit

Turn the lamp ring on the front side of the lamp to the left. Now the unit can be pulled off from the housing. Rinse the O-ring and apply a thin coating of silicone grease. Replace the lamp ring and turn it to the right until it is firmly in place.

Replacing bulb (Halogen Unit)

Turn the lamp ring on the front side of the lamp to the left. Now the unit can be pulled off from the housing. Remove the bulb and insert a new bulb. Ensure that the bulb is located all the way in the socket. Rinse the O-ring on the housing and grease it with silicone grease. Replace the front glass and turn it to the right until it is firmly in place. Check the lamp for correct operation.

Remark:

- Always use the light bulb advised by the manufacture. (12 Volt GY6,35 socket max. power 50 Watt)
- Never touch the light bulbs with your bare fingers, this will cause the light bulb to burn out prematurely, use a clean tissue or cloth.

Connection of the battery tank PR1206 / PR1209 / PR1213 onto the tank or BCD

First connect the tank plate onto the bottle or jacket belt.

You can use two methods:

1. Connect the tank plate with stainless steel belts on the bottle
2. Connect the tank plate on the BCD belt by guiding the belt through the slots in the plate (see figure).
Now you can connect the battery pack onto the plate by depressing the locating button, pushing the battery pack down onto the locating part then, onto the securing port and release the locating button

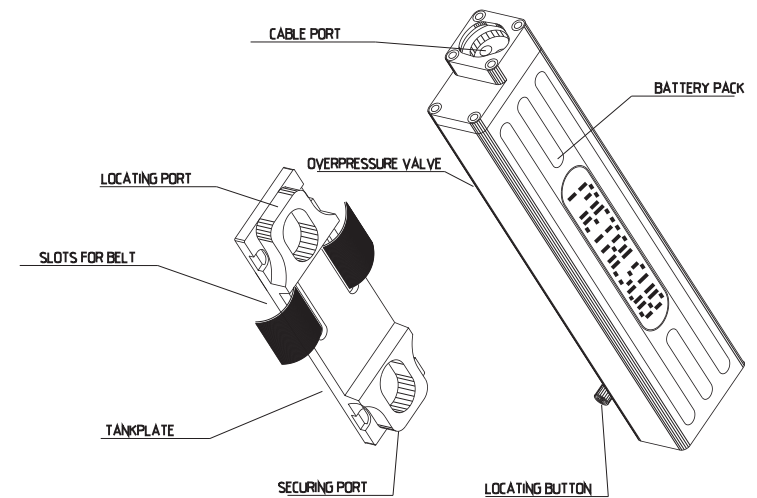

Connection of the battery tank FX1204 / FX1206 / FX1209 onto the cilinder

Slide the bracket of the battery tank over the belt of the stabilizing jacket.

Close the belt securely.

General:

- After each dive, soak the lamp in clean fresh water for a few minutes. (Note: not the contacts in the cable port on the battery tank!!)
- Rinse the dive light under running water to remove all traces of sand and salt.
- Avoid physical impact.
- Avoid overheating and direct exposure to sunlight.