

Technical information

Cable light	HID125
Material	Aluminium*
Size	65 x 220
Weight above water	0,70 kg
Weight under water	0,1 kg
Bulb type	HID Xenon
Variable light power	24 Watt
Colour temperature	Ca. 6000K
Luminous flux	appr. 1500 Lumen
Cable lenght	90 cm.

Battery pack	PR1205/FX1206	PR12085/FX1209	PR 1213
Material	Aluminium	Aluminium	Aluminium
Size	65 x 75 x 340	65 x 75 x 340	65 x 75 x 480
Weight above water	2,7 kg	2,9 kg	3,7 kg
Weight under water	1,6 kg	1,7 kg	2,7 kg
Battery type	Nicad	NIMH	NIMH
Battery power	12 Volt 5,5 Ah	12 Volt 9 Ah	12 Volt 13 Ah
Charger	MP1100	MP2500	MP2500
Charging time	6 hours	4,5 hours	7 hours
Capacity variable lightpower 28-50 Watt	appr. 140 min. (temp. 20°C)	appr. 250 min. (temp. 20°C)	appr. 360 min. (temp. 20°C)
Quick release system	yes/no	yes/no	yes

* In accordance with American Military Standard MIL-A-8625-E type 3 class 2.
Also the coating is impregnated with Teflon.

Warranty

The Metalsub torch warranty will start on the date of purchase. The warranty period is two years and will only count when the torch has been used in the way the manufacture advises and has explained in the outlines. During this warranty period we will repair all problems that are caused by manufacture related mistakes. We will take no responsibility for damage that is done through misuse or normal wear and tear of the Metalsub Diving Light for whatever reason. The battery itself has a warranty period of one year, with the same remarks for misuse. The lightbulb itself has no warranty!

We will give no warranty when any person has carried out any repair or rebuilding on our products by themselves!
All goods being returned for warranty must be returned prepaid, sufficiently packaging under te owners risk to :

DEALER



The Netherlands

Users Manual



METALSUB Cable light HID125 € 05

**Cable light HID 125 batterypack PR1205/12085/PR1213
battery pack FX1206/1209**

SAFETY PRECAUTIONS!

- A. Read this manual carefully before using the divelamp
- B. When you are diving in situations where your life can depend on having sufficient light (for instance in caves or on wrecks), make sure you always take a back-up light with you.
- C. Prior to airtravel, disconnect the cablelamp from the batterypack. Also discharge the batterypack, so as to prevent overheating should the lamp be switched on by accidental impact or mishandling.
- D. To prevent a short-circuit, it is essential to plug the battery tank with the supplied tankplug(s).
- E. Always use the supplied charger.
- F. Charging the lamp: - always in a dry and well ventilated place
- ambient temperature between 0 and 30°C
- never by open fire
- G. When changing lights, always disconnect the light from the battery tank first.
- H. Never shine the light directly into eyes, this can cause eye damage.

USING THE CABLE LIGHT HID200

Charging the batterytank (MP1100/MP2500 charger)

The charger is suitable for mains between 100-240 Vac. We deliver the battery pack empty, so it is important to charge the empty pack completely with a full charge cycle.

Make sure that the connectors are completely clean and dry. Securely plug the charge connector into the batterypack . The charger is fitted with a Delta-V charge controller. The chargecontroller switches over to pulse charging as soon as the battery reaches its full power. Please wait until the LED on the charger lights green continuously before you disconnect the charger from the battery pack.

Battery test: the LED indication will flash red 5 sec.

Charging: The LED indication lights red continuously.

Batterypack full / trickle charge: the LED indication lights green continuously.

Warning:

Always use the supplied charger !!! The use of other chargers can damage the battery cells inside!!!

The cable-light connector

The connection of the cable-light to the battery pack is done by placing the connector in the waterseal connector seat on the battery pack. The connection is made with a little inward push and a turn to the right. Disconnection is done by doing the same sequence in reverse.

Make sure that the connectors are completely clean and dry. When necessary, clean the O-ring and use a little bit of silicone grease.

Warning:

Never disconnect the the light from the battery pack under water!!!! This will damage the connector inside the battery pack!!!!

Turning the light on or off

The light is switched on by sliding the locking bolt on the switch back and then turning the switch to the right. While you are turning the switch to the right, the light comes on at full power – let it burn in this position for about five seconds (this improves the life span of the light). You can then continue to turn the switch until it clicks (stops) into the 90-degree position; the light dims to minimum power. To turn the light off, rotate the switch back to the left until it clicks into the off position. To lock the light, slide the locking bolt back and rotate the switch to the left until it clicks (locks) into the locked position.

Comments

To make sure the light doesn't overheat or causes burn damage to objects in its immediate vicinity, it is advisable to use it only underwater.

When the light is not in use, turn the switch fully to the left (locking position)

Never store the batterypack uncharged for a long period. If the batterypack is not used for a long period, we advise you first to charge the batterypack completely and then every three months to dis- and recharge the batterypack completely. When the battery has been stored uncharged for a long period, it can lose its charge entirely. This can cause irreparable damage to the battery cells.

Changing the HID bulb

Consult your dealer.

Note: never touch the HID bulb with your fingers, this can cause it to burn out prematurely.

The LED display on the back of the lamp housing tells you the following:

LED green:	100% - 50%	remain capacity
LED orange:	50% - 20%	remain capacity
LED red:	20% - 10%	remain capacity
LED red blinking:	10% - 0%	remain capacity left: the light will automatically switch to dimmed position (28 watt).

Note: These values are guiding values only and depend very much on water temperatures and the type of battery tank! The values shown above were measured at a water temperature of 20°Celsius. In colder water (for instance 10°Celsius or less) the LED light will go from green to orange in just a few minutes.

Connection of the battery tank PR1205/PR12085/PR1213 onto the cilinder or BCD

First connect the tank plate onto the bottle or jacket belt.

You can use two methods:

1. Connect the tank plate with stainless steel belts on the bottle
2. Connect the tank plate on the BCD belt by guiding the belt through the slots in the plate (see figure).
Now you can connect the battery pack onto the plate by depressing the locating button, pushing the batterypack down onto the locating part then, onto the securing port and release the locating button.

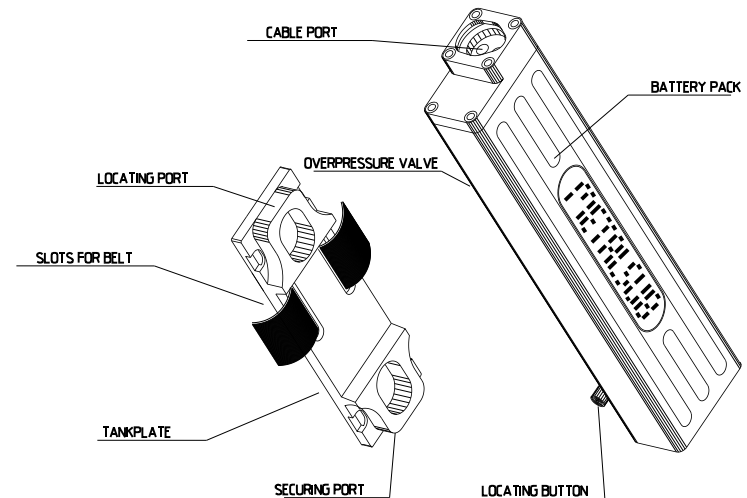

Connection of the battery tank FX1206 / FX1209 onto the cilinder

Slide the bracket of the battery tank over the belt of the stabilizing jacket.

Close the belt securely.

General:

- After each dive, soak the lamp in clean fresh water for a few minutes.
- Rinse the dive lamp under running water to remove all traces of sand and salt.
- Make sure the sockets are dry. After each dive, we suggest blowing in compressed air (from the dive tanks)
- Avoid physical impact.
- Avoid overheating and direct exposure to sunlight.